

EFFICIENT INITIAL SAMPLE INSPECTION REPORTS – QUALITY ASSURANCE IN CATIA V5

CENIT's QA REPORT software builds a bridge between product development and quality planning/quality assurance. The solution, which is fully integrated into CATIA V5, supports users by automatically numbering and certification-stamping design drawings. Transmission errors are prevented by an automated derivation of all inspected criteria into an initial sample inspection report (ISIR), also known as First Article Inspection (FAI) in the aerospace industry. This accelerates not only the production part approval process (PPAP), but also the development of inspection plans for serial production monitoring.

► PRODUCT FEATURES

- Collision-free and flexible positioning of certification stamps
- Simple extraction of the quality-relevant aspects of design drawings, e.g. in the form of initial sample inspection reports in various languages, and compliance with pre-set norms
- Easy verification and documentation of drawing modifications
- Integrated search function can search all attributes of stored design drawings
- Inspection numbers of deleted drawing attributes are stored in a quarantine list to prevent re-use
- Export of QS data in various output formats – XML file, comma-divided text file, Excel table, and Q-DAS ASCII transfer format (gs-STAT)
- Re-import of previously exported XML files into modified drawings; list of deviating attributes
- Integration of numerous VB-script macros for a wide range of automated work steps

► BENEFITS

- Transparency of internal processes because generated quality data is integrated into existing PDM systems
- Consistent communication throughout the development process
- Simplification of internal and external communications thanks to quick location and analysis of drawing attributes
- Simple forwarding of measurement criteria to offline programming systems via the industrial-standard Q-DAS ASCII transfer format
- Replicable change process with automatic protocol of modified measurements and tolerances
- No more time-consuming manual positioning of certification stamps

- Consistently high quality thanks to error-free evaluation and downstream use of all measurements and tolerances
- Simple customization to enterprise-specific requirements via individually configurable parameters
- Mapping of asynchronous development processes by permitting QA read access only to original CAD data

► TARGET SECTORS

- All manufacturing enterprises

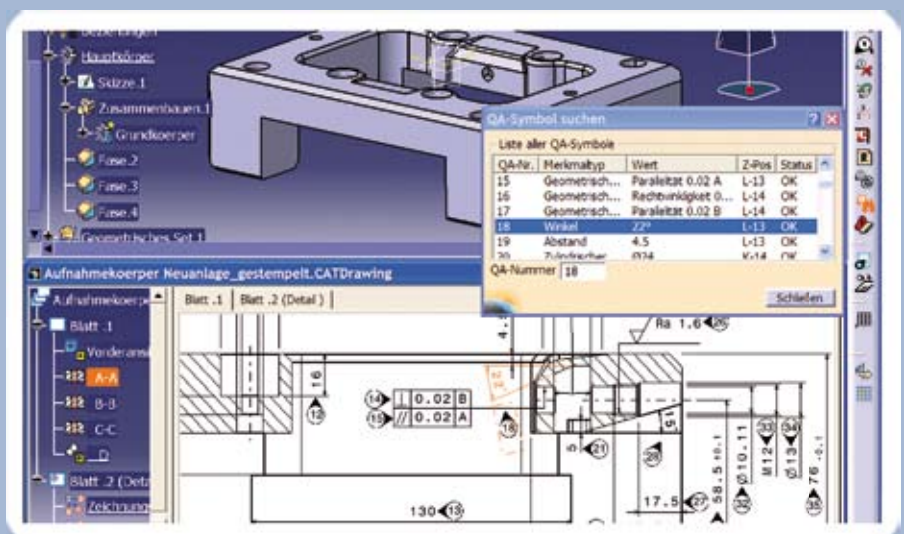

CENIT LOCATIONS: ADRESSES & CONTACT

GERMANY

CENIT Stuttgart

Industriestraße 52-54
D-70565 Stuttgart
Tel.: +49 711 7825-30
Fax: +49 711 7825-4000
E-Mail: info@cenit.de
Web: www.cenit.de

CENIT Berlin

Eichenstraße 3b
D-12435 Berlin
Tel.: +49 30 884580-0
Fax: +49 30 884580-99

CENIT Düsseldorf

Max-Planck-Str. 17
D-40699 Erkrath (Unterfeldhaus)
Tel.: +49 211 530652-0
Fax: +49 211 530652-99

CENIT Frankfurt

Lyoner Straße 20
D-60528 Frankfurt
Tel.: +49 69 668018-0
Fax: +49 69 668018-8

CENIT Hamburg

Heidenkampsweg 51
D-20097 Hamburg
Tel.: +49 40 2533466-0
Fax: +49 40 2533466-88

CENIT Hannover

Großer Kolonnenweg 21
D-30163 Hannover
Tel.: +49 511 54275-0
Fax: +49 511 54275-88

CENIT München

Paul-Gerhardt-Allee 50a
D-81245 München
Tel.: +49 89 829209-0
Fax: +49 89 829209-99

CENIT Oelsnitz

Kurt-Mauersbergerstr. 9
D-09376 Oelsnitz
Tel.: +49 37298 3039-0
Fax: +49 37298 3039-30

CENIT Saarbrücken

Innovationsring 9
IT Park Saarland G1
D-66115 Saarbrücken
Tel.: +49 681 76190-0
Fax: +49 681 76190-99

SWITZERLAND

CENIT (Schweiz) AG

Hungerbühlstrasse 22
CH-8500 Frauenfeld
Tel.: +41 52 7247777
Fax: +41 52 7247778
E-Mail: info@cenit-ag.ch
Web: www.cenit.de

ROMANIA

S.C. CENIT S.R.L.

Str. Calea Chisinaului
Nr. 104-106 bis, Iasi
Tel.: +40 332 430574
Fax: +40 332 430572
Web: www.cenit.ro

USA

CENIT North America Inc.

691 N Squirrel Rd, Suite 275
Auburn Hills, MI 48326
USA
Tel.: +1 248 276-8540
E-Mail: info@cenit.us
Web: www.cenit.us

FRANCE

CENIT France

15 Chemin de la Crabe
FR-31300 Toulouse
Tel.: +33 567310220
Fax: +33 561158805
Web: www.cenit.fr

